

## EM-10000 Remote Air Monitor

The Particles Plus EM-10000 is designed for outdoor particulate and gas monitoring. These robust monitors provide reliable, accurate measurement of airborne contamination allowing for the detection of environmental and public health concerns. The first real time monitor to provide 6 accurate particulate size channels.



### Realtime Data

6 particle size channels recorded by the EM-10000 Monitor are stored in an internal non-volatile memory at user-defined data sampling rates (1 second to 99 hours). The high time-resolution of the Model EM-10000 measurements provides a near-instantaneous look at changing airborne particulate concentrations, leading to a well-defined model of local point source influences that may disproportionately affect air quality.

### Internet-Enabled

Particles Plus systems are configured to allow users to push real-time data to the cloud where sensor outputs can be visualized by authorized stakeholders.

### Fully Integrated Low-Cost Air Quality Sensor System

Integration of additional sensors for measurement of environmental and meteorological parameters (relative humidity, temperature, barometric pressure, (optional) carbon dioxide - CO<sub>2</sub>, and total volatile organic compounds -TVOC) offers a more complete view of air quality.

### Applications

- Airborne Pollution and Environmental Research
- Perimeter or Fence-line Monitoring for Construction, Remediation or Hazardous Waste Sites
- Mine and Quarry Fence-line Monitoring for dust control operations
- City Wide or Community Air Pollution Monitoring
- Roadside Emissions Monitoring
- Medical Facilities Property Monitoring
- Power Line Wild-Fire Monitoring
- Environmental Disasters
- Monitor for 24 hours a day, 7 days a week, 365 days a year

### Features and Benefits

- Concurrent measurement of multiple, user selectable PM sizes from 0.3um to 10 µm including TPM of particles up to 25 µm
- Closed-loop humidity control for incoming airstream (to provide more accurate particulate sizing)
- Closed-loop condensation control within the enclosure
- Perform in-line gravimetric sample collection for correction reference calibration
- ULTRAGUARD® Fiberglass reinforced polyester NEMA 4 rated outdoor tamper-proof enclosure with internal thermal control
- Optional pole or tripod mount options
- Optional Cloud based data management software subscription available for remote

## Specifications

<b>Model</b>	<b>EM-10000</b>
Size Range	0.3 (300 nm) to 25 $\mu$ m
Number of Channels	6 channels
Concentration Limit	15,000,000 Particles/ft <sup>3</sup> @ 10% coincidence loss (~6.5 mg/m <sup>3</sup> )
Light Source	Long life laser diode
Count Modes	Cumulative/differential count/m <sup>3</sup> & count/ft <sup>3</sup> , and mass concentration (PM)
Calibration	NIST traceable
Vacuum Pump	Internal rotary vane vacuum pump - 0.1 CFM (2.83 LPM) Flow rate
Airflow	Internally monitored flow control
Audible Alarm	Optional external Piezo 120 dB sounder
Communication Modes	Internal Ethernet and USB - Allows for variety of connectivity options
Optional Communication Modes	Wireless 802.11 b/g, RS485 or RS232, Ethernet Fiber Bridge, 4G Cellular
Environmental Sensor	Temperature and relative humidity probe: -4° to 122°F (-20° to 50°C) $\pm$ 1°F (0.5°C), 0 -100% $\pm$ 2%RH
Optional Sensors	NDIR CO <sub>2</sub> (0-5000 ppm, resolution 1 ppm, accuracy $\pm$ 1% FS, Response rate 20 seconds) TVOC PID, 0-50 ppm / min. detection level 5 ppb, accuracy $\pm$ 1.5%, Response rate <3 seconds
Alarm	Alarms for all particle values, environmental sensors, flow and sensor failure
Calibration	Particle sensor recommended once per year
User Calibration	Field Calibration of Temperature, Humidity, CO <sub>2</sub> and TVOC possible with included utility software
External Surface	ULTRAGUARD® Fiberglass reinforced polyester - compression molded SMC box and Cover
Dimensions (L x W x H)	10.6" x6.01" x 12.14" (26.9 cm x 15.2 cm x 30.8356 cm) includes barb fittings
Weight	12.5 lbs. (5.66 kg)
Accessories	Quick start guide, operating manual on USB flash drive, mounting feet
Optional Accessories	Printed manual, data cable, pole mounting hardware kit
Buffer Memory	Internal 45,000 sample records (rotating buffer) including particle count data and environmental data
Sample Time	1 second to 99 hours
Power	110 to 240VAC 50/60 Hz universal in-line power supply
Operating Conditions	-4° to 122°F (-20° to 50°C) / 20% to 95% non-condensing
Warranty	1 Year, Extended warranties available

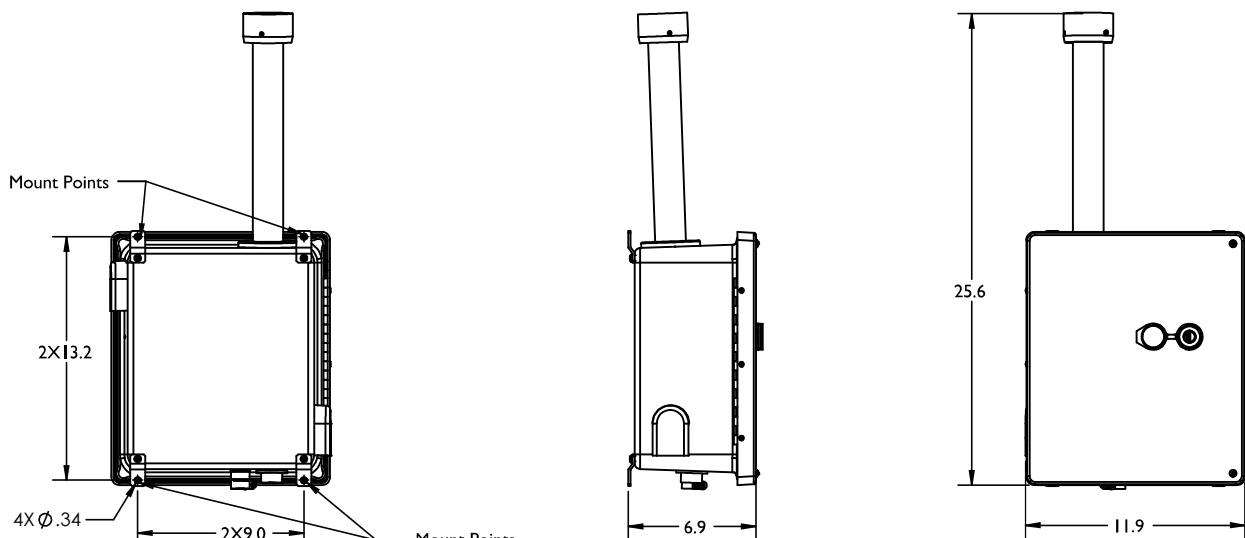

**DISTRIBUTED / MARKETED BY:**

**innospectra**  
www.innospectra.com

Patents US 9,140,638, US 9,140,639, US 9,157,847, US 9,158,652, US 9,677,990. Additional Patents Pending.

Particles Plus, Inc. reserves the right to change specifications without notice. Contact hello@particlesplus.com or your local distributor for more details. Particles Plus and the Particles Plus logo are trademarks of Particles Plus, Inc. ©2019 Particles Plus, Inc. All rights reserved.



31 Tosca Drive  
Stoughton, MA 02072 U.S.A.  
+1-781-341-6898 phone  
www.particlesplus.com